



The Flush Finish Trimless Door Frame
**Installation Instructions
and Ordering Information**



CLEAN LINES!... The Flush Finish Door Jamb System

Manufactured by STUDCO Building Systems

Step 1

Verify if you are using prefit or full & square doors.
Insure that the stud opening is square and level

Important: The manufacturer strongly recommends a wood stud or a minimum 20 gauge 0.030 metal stud on both sides of the opening.

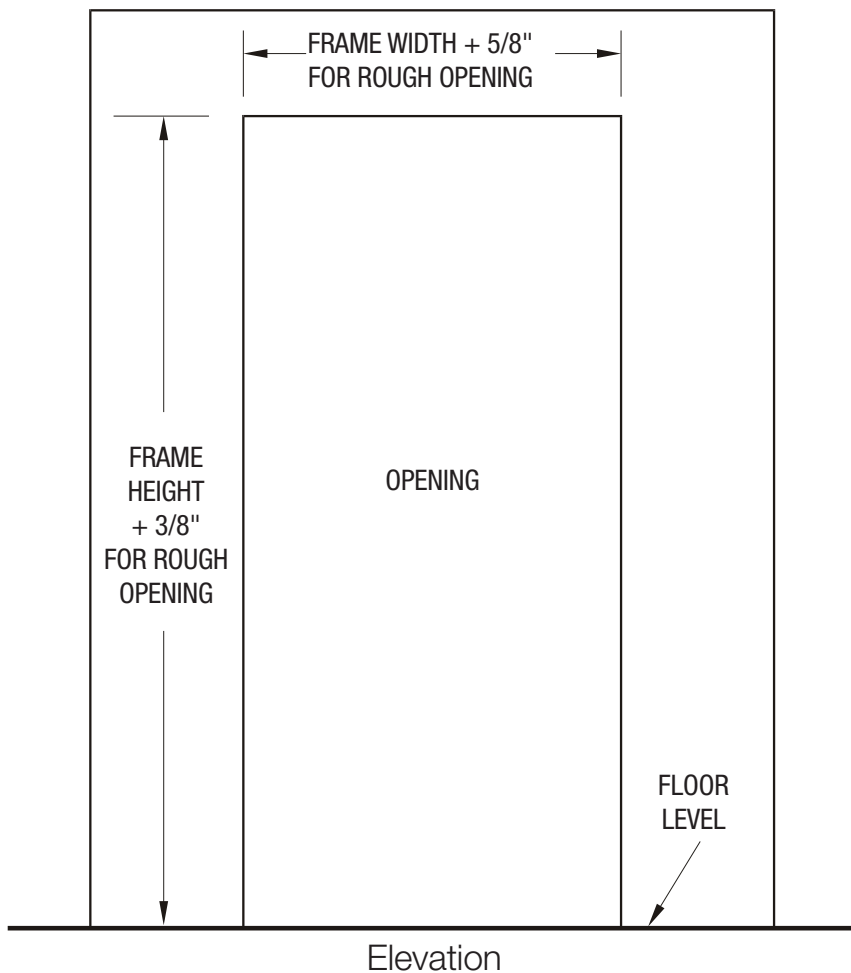

Full + Square Example

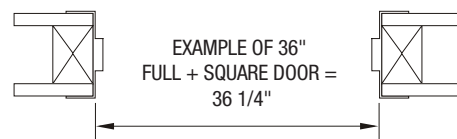

Prefit Example

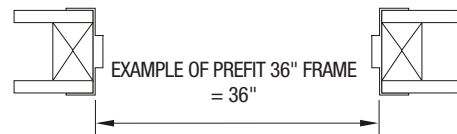

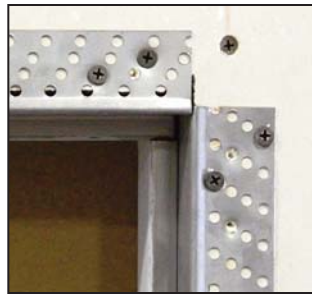

Step 2

- Fasten hinge side first, making sure jamb is level and as tight against stud opening as possible.
- Then screw at 8" centers up stile, screwing back through drywall into stud jamb.
- Double screw all ends as *Detail D*. and beside hinge position - both above and below hinge if using concealed hinges as *Detail E*.

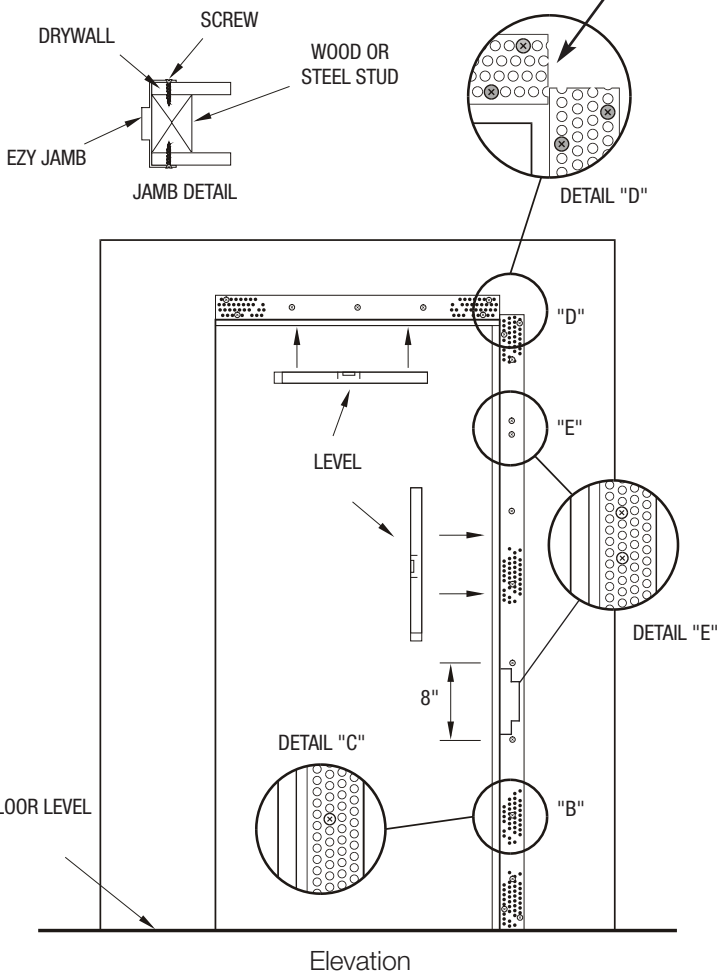

Step 2A

HEAD INSTALLATION INSTRUCTIONS

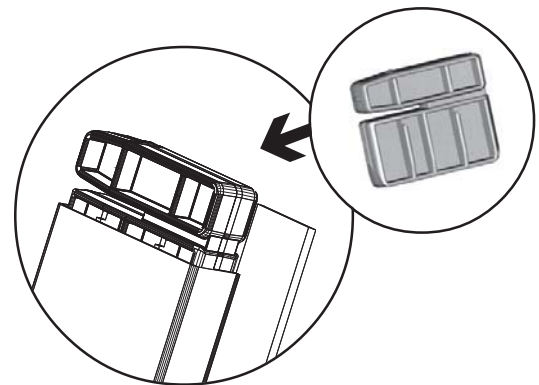

Head joiner as inserted in jamb.

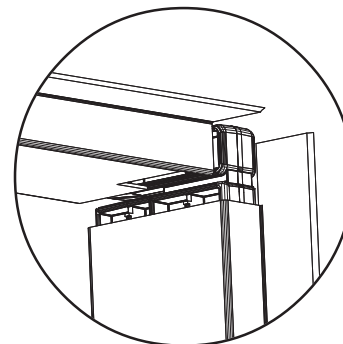

Locate head into joiner and make flush with jamb so the head joiner is not seen.

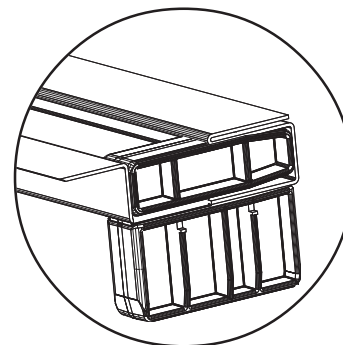

Remove the remaining head joiner out of the strike jamb into the end of the head (as shown) to receive the strike jamb.

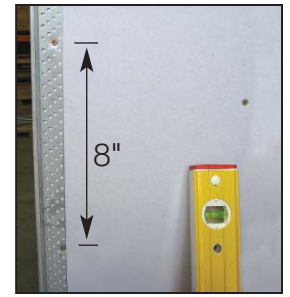

Step 3

Fasten the final vertical section (strike jamb) below the head section. Insure that the spacing between the two vertical sections are spaced evenly at the required distance.

Step 4

Insure the perforated side strips sit flat against the drywall to enable the jamb sections to be easily mudded into the wall surface. **All the corners must be paper taped and mudded in as Detail F.** Finish the jamb with drywall compound. Hang the door in position leaving about 1/8" clearance from the top and the hinged side using the Ezy Jamb Standard or Invisible Hinges. Surface mount the striker plate into position to align with the latch plate punching.

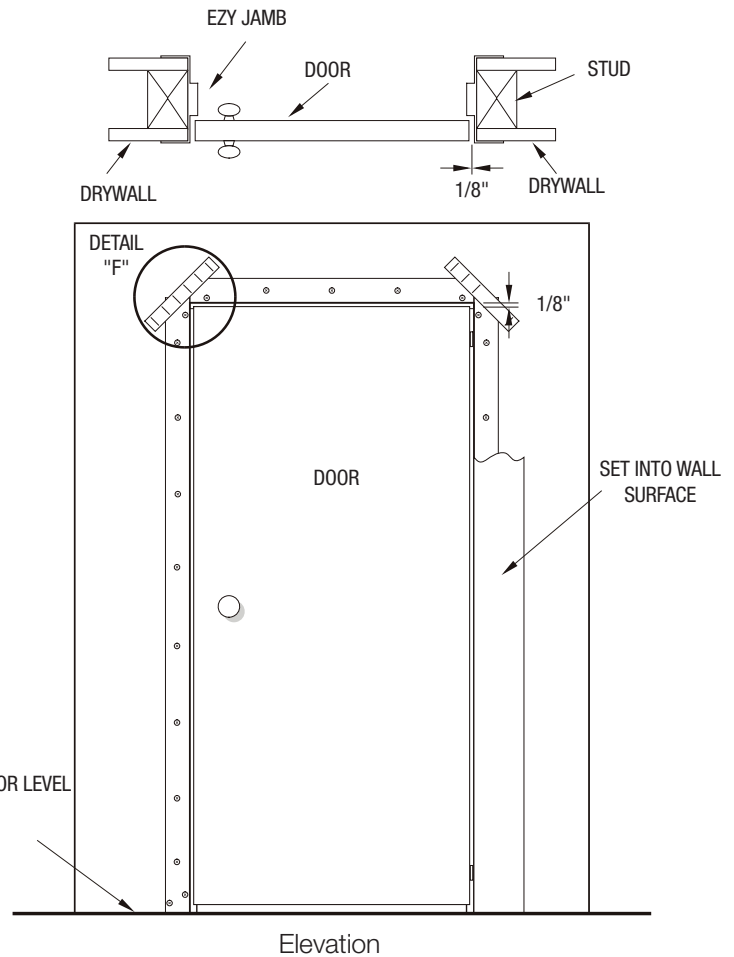
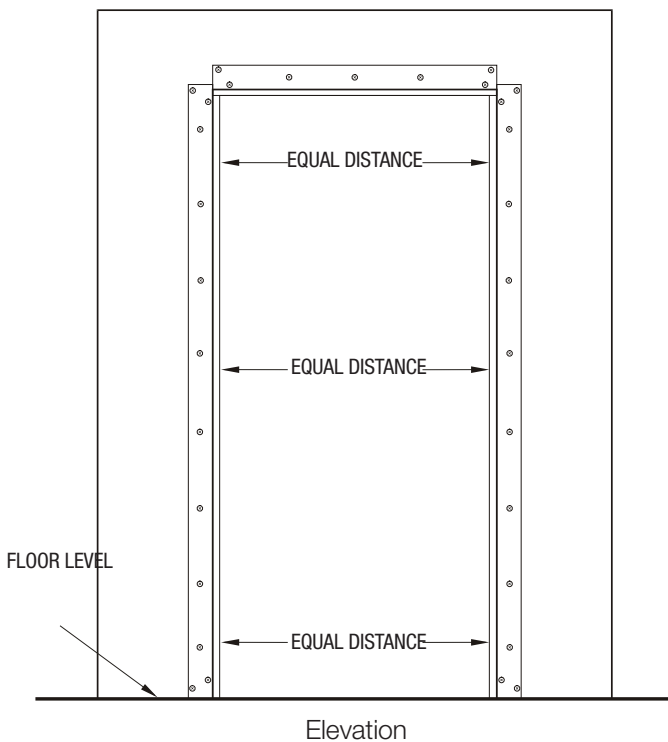

Information printed in this document or communicated by the designers, manufacturers, distributors or any agent is subject to change without notice to allow further development in design, manufacture and technology.

Installation Detail

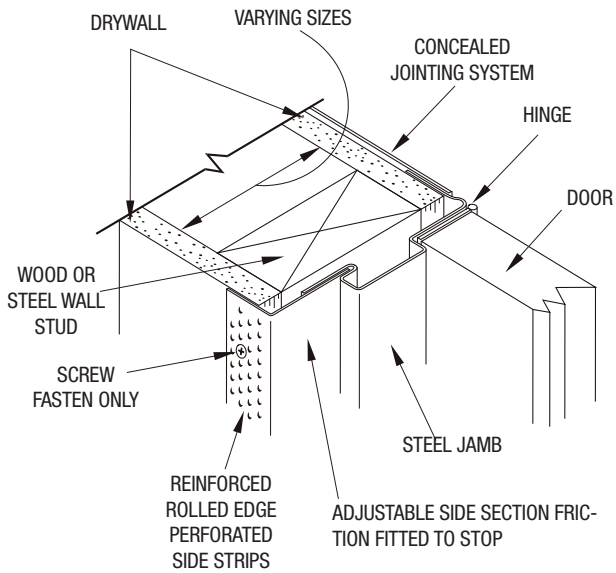

1 3/8" DOOR



1 3/4" DOOR

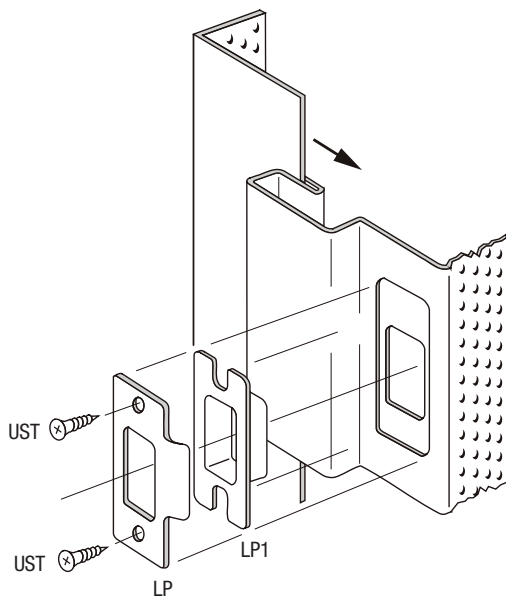

STRIKE PLATE INSTALLATION DETAIL

For invisible hinges see - 'Invisible Hinge Installation'



EZY jamb®

cavkit®

FINISHING DETAIL FOR CAVITY SLIDER*

**Trims only*

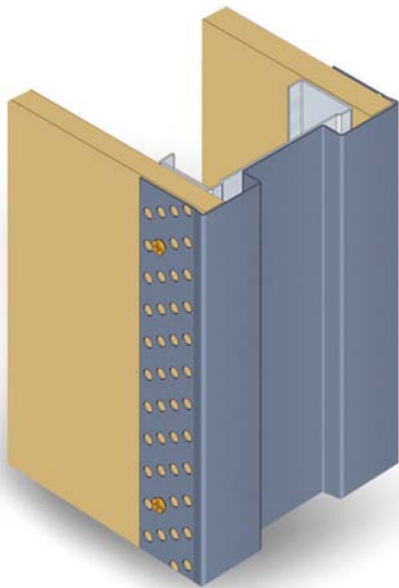

Custom made closer cap

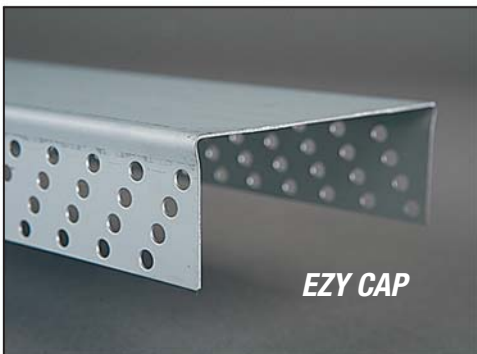

EZY CAP



EZY REVEAL



THE FLUSH FINISH CAVITY SLIDER TRIM KIT

Cavkit can be used to transform standard cavity sliders into architrave free, flush finish cavity sliders. This also complements and tones in with the Ezyjamb® flush finish door jamb system. The Cavkit is made up of Ezyreveal® and Ezycap® to trim and cap the plaster edges around the door penetration. Custom made closer cap can be produced to suit any specification.

For more information visit the Ezyjamb website on www.ezyjamb.com.

EZY cap®

EZY reveal®

CLEAN LINES!... The Flush Finish Door Jamb System

Cavkit – Typical Head Detail

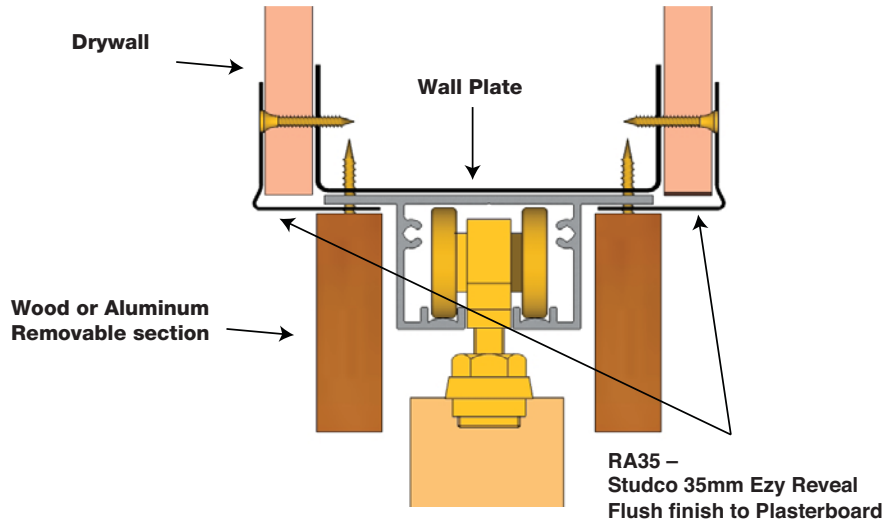

Cavkit – Plan View

- Cavkit with ezy cap

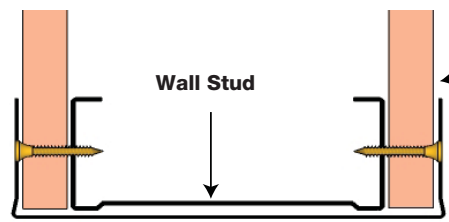

Studco Ezy Cap:

Wall Thickness	Ezy Cap Part No.
77mm	FC79
84mm	FC86
90mm	FC92
96mm	FC98
102mm	FC104
110mm	FC112
117mm	FC118
124mm	FC127

Cavkit – Plan View

- Cavkit with Closer Cap

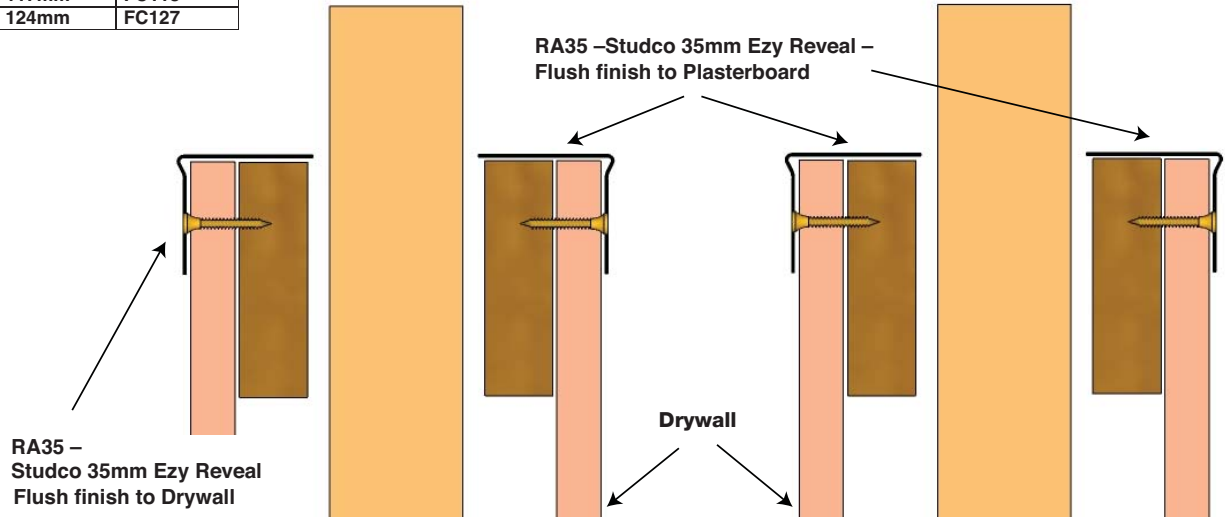
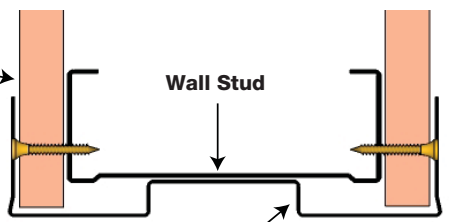

FLUSH FINISH ACCESSORIES

ALUMINIUM SKIRTING

SK80-36 80mm x 1.6 Flat Natural Anodised Aluminium Skirting

SK100-36 100mm x 1.6 Flat Natural Anodised Aluminium Skirting



SK100BL-36 100mm Natural Anodised Direct Screw Fix Skirting



SECTION DETAILS

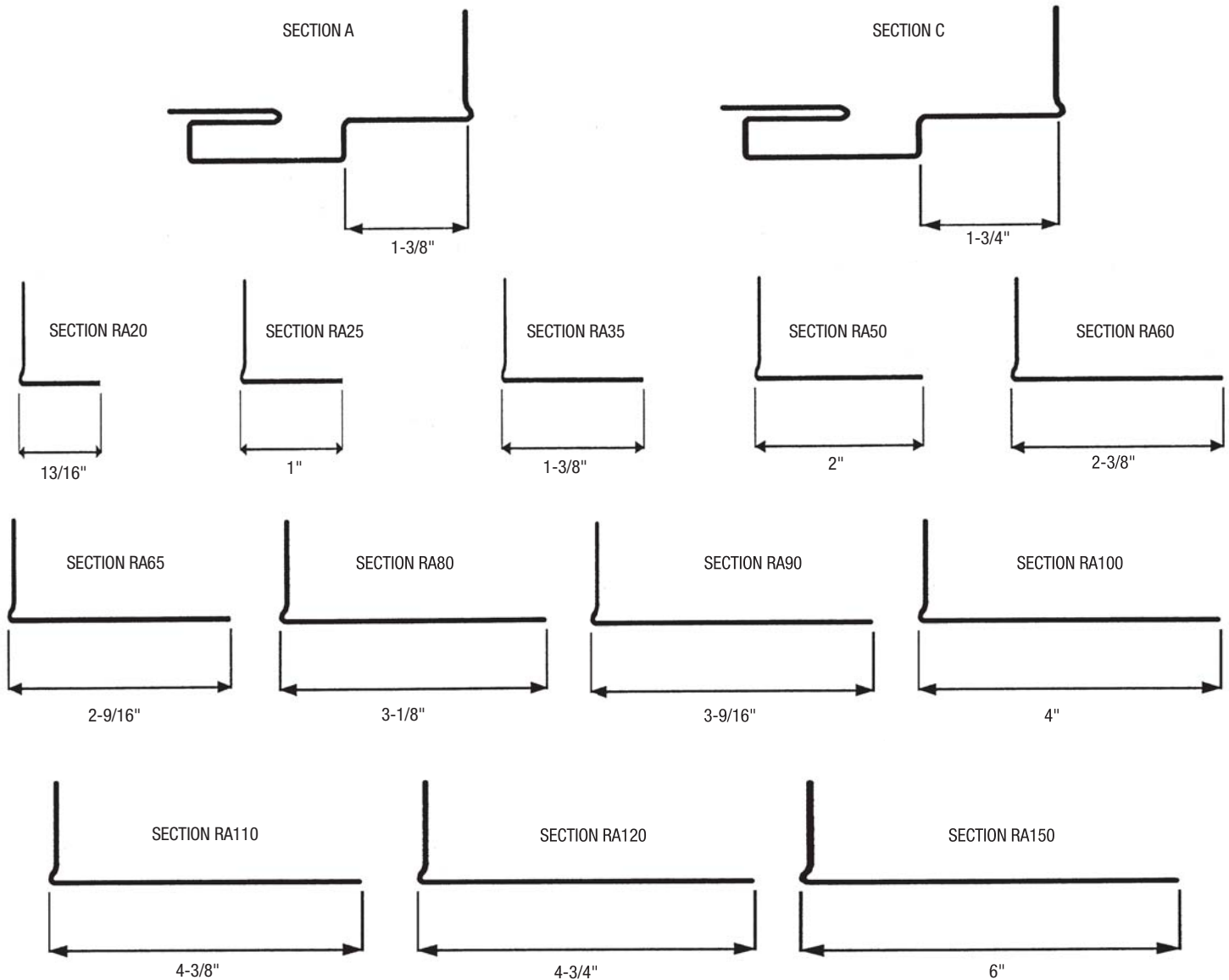

section a combinations	FINISHED THICKNESS WALL TOLERANCES	
	MIN. IN.	MAX. IN.
SECTION A & RA20	3-3/8"	3-1/2"
SECTION A & RA25	3-3/8"	3-11/16"
SECTION A & RA35	3-9/16"	3-15/16"
SECTION A & RA50	4-3/16"	4-9/16"
SECTION A & RA60	4-9/16"	4-15/16"
SECTION A & RA65	4-3/4"	5-1/8"
SECTION A & RA80	5-4/16"	5-3/4"
SECTION A & RA90	5-3/4"	6-1/8"
SECTION A & RA100	6-1/8"	6-1/2"
SECTION A & RA110	6-1/2"	6-15/16"
SECTION A & RA120	6-15/16"	7-5/16"
SECTION A & RA150	8-1/8"	8-1/2"

section c combinations	FINISHED THICKNESS WALL TOLERANCES	
	MIN. IN.	MAX. IN.
SECTION C & RA20	3-1/2"	3-7/8"
SECTION C & RA25	3-5/8"	4"
SECTION C & RA35	4"	4-3/8"
SECTION C & RA50	4-1/2"	4-7/8"
SECTION C & RA60	5"	5-3/8"
SECTION C & RA65	5-1/8"	5-1/2"
SECTION C & RA80	5-9/16"	6"
SECTION C & RA90	6"	6-1/2"
SECTION C & RA100	6-1/2"	6-7/8"
SECTION C & RA110	6-7/8"	7-3/8"
SECTION C & RA120	7-3/8"	7-3/4"
SECTION C & RA150	8-1/2"	8-7/8"



Instructions on filling out the EZY-JAMB Order Form

Company Name and Address:

This should be filled in with the Purchasing Company's actual address, contact name, phone & fax number.

Jobsite Name & Address:

This should be filled out with the delivery address if different than the one above. If it is the same, please write "same".

Finished Wall Thickness:

Total thickness of the studs and the drywall on the finished wall.

Door Thickness:

Door thicknesses of 1-3/8" & 1-3/4" are available. Determine if using Prefit or Full & Square doors.

Example: Prefit frame

3'0" x 7'0" and door is 2'11-13/16" x 6'11-1/8"

Full & Square

Frame is 3'0-1/4" x 7'1" and door is 3'0" x 7'0"

Door Width x Height:

The actual dimensions of the door are needed- we will oversize the frame to meet each application.

Example:

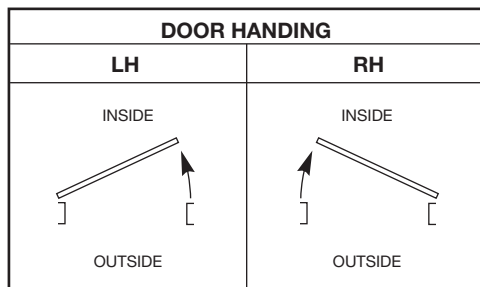

Strike Plate Type/Height:

The measurement from the top of the door to the center of the strike plate punch.

Hinge Hand:

either LH or RH. Example below.

Type of Hinges:

Invisible hinges (See 'Invisible Hinge Chart') or Stainless Steel (SS), Oil Rubbed Bronze (OB), Satin Brass (SB), Polished Chrome (PC), Polished Brass (PS), or Satin Chrome (SC).

Quantity of Hinges:

Quantity of hinges per door is required.

Quantity:

Quantity of door frames of this size that is required.

Comments:

All the other information that is needed- i.e. Type, Fire rating etc...

***Any other questions
can be answered by our well trained
sales professionals.
Feel free to give us a call.***

MANUFACTURED BY:



800.675.8023
1888 EZY JAMB
www.ezyjamb.com
Email: sales@ezyjamb.com

DISTRIBUTED BY: